

### Application

The 3112W is a full-range, two-way system designed for a wide variety of speech and music applications, such as clubs, churches, or concert settings.

### Cabinetry

The cabinet design uses a 13 ply 3/4" high quality baltic birch plywood with dado joints, recessed baffle and a 16 gauge front perforated grill for long lasting durability. The baffle is cut from 1" MDF to enhance acoustical properties and to give the components a rigid interface. Two Neutrik Speakon connectors and two Neutrik parallel 1/4" jacks are installed on all speakers in the 3000 series.

### Covering Options

The cabinet comes coated in black Duracoat. It is also available in white Duracoat and a natural birch finish. Please refer to price sheet for upgrade pricing.

### User Adjustable Response Curve

The user can adjust the frequency response curve, by means of a switch mounted on the jackplate, to optimize the speaker output for vocal enhancement.

### Transducers

The two-way cabinet is loaded with a 12" cast aluminum low frequency driver and a 1" titanium high frequency compression driver. The titanium high frequency driver is coupled with a durable cast horn for proper dispersion. The cabinet is tuned by means of a vented port set at the optimum frequency.

### High Frequency Protection

The 3000 Series features our exclusive "OPC" system (patent pending) with LED indicators mounted on the baffle. A green LED which lights when there is signal present - and a red LED which lights when the OPC (overload protection circuitry) senses an overload condition in the HF driver. The OPC disconnects the HF driver temporarily, and the red LED flashes, indicating an overload. When the HF driver cools, or the power is decreased, the OPC automatically resets itself and signal is restored to the HF driver.

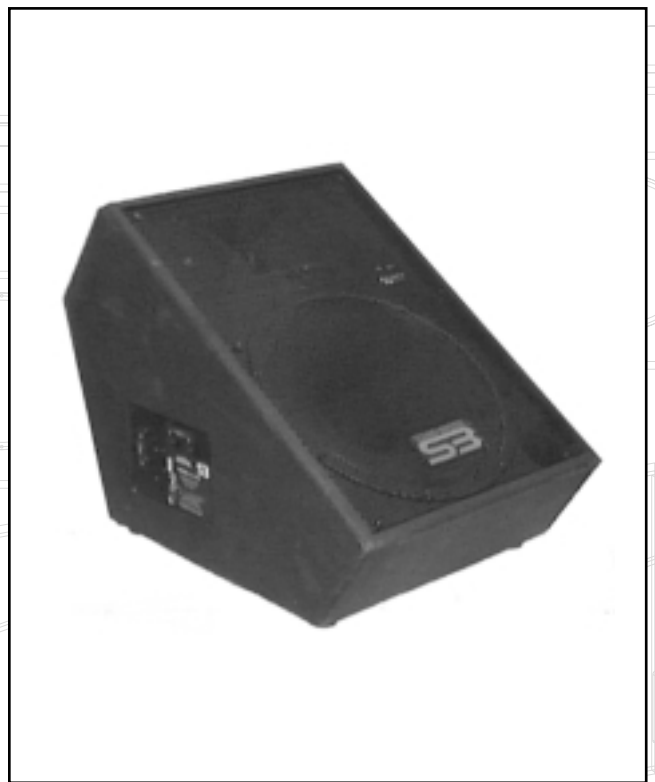

### Specifications

<b>Frequency Response:</b>	65hz-18Khz
<b>Power Handling:</b>	450w (cont.)
<b>Sensitivity (1 watt/meter):</b>	98dB
<b>Nominal Dispersion:</b>	70v x110h
<b>Impedance:</b>	8 Ohms
<b>Transducer Components</b>	
Low Frequency:	12" woofer
High Frequency:	1" titanium
<b>Audio Input Connections:</b> Two Neutrik Speakon connectors and two parallel jacks.	
<b>Enclosure:</b>	Vented
<b>Crossover:</b>	4th Order LR
<b>High Frequency Protection:</b>	Yes
<b>Steel Pole Mount:</b>	No
<b>Physical</b>	
Dimensions (H x W x D):	15.5" x 15" x 21.8" (39.4cm x 38cm x 55.4cm)
Weight:	43 lbs./19.6 Kg

### Warranty Information

The 3000 Series high definition speakers feature a 10 year warranty. Please refer to the warranty information card shipped with all Sound Bridge speaker products.

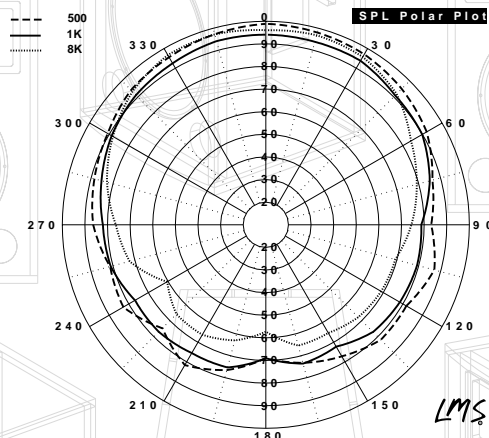
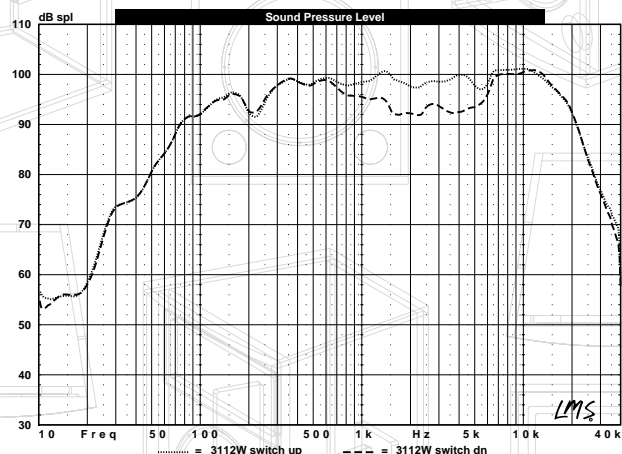

**3501 Interstate 35E • Waxahachie, TX 75165 • 800 628-9084 • FAX (972) 935-0539**

*Sound Bridge Acoustic Labs is dedicated to excellence. Therefore, we retain the right to improve design, materials and workmanship. (Or in legal jargon: Prices and Specifications are subject to change without notice.)*